

RAK-DUCT-01

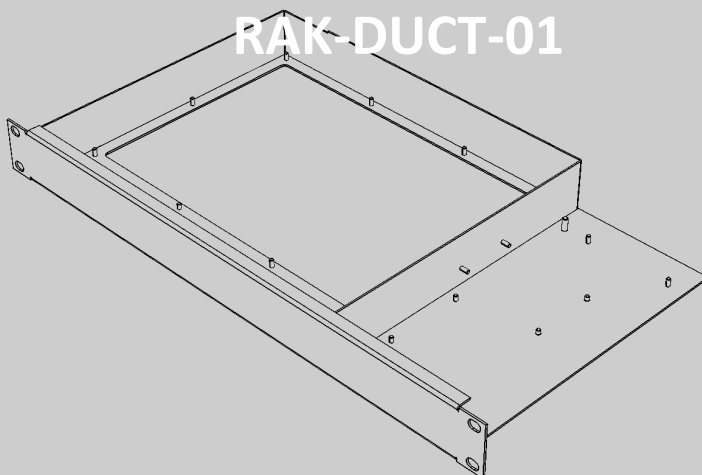

- OPTIMUM V2000 COOLING
- SIMPLE INSTALLATION

OVERVIEW

The RAK-DUCT-01 is used in conjunction with the RAK-FAN-01 in V2000 based PAVA systems. The unit is installed between V2000 amplifier mainframes to direct airflow through vents, ensuring optimum cooling of amplifier modules and associated components.

The unit is designed to be installed in standard 19" equipment racks and is supplied with necessary fixings and installation instructions.

Please consult the ASL System Design Guide documentation for more information.

SPECIFICATION

Temperature / Humidity Range...refer to V2000 specification
 Dimensions (H x W x D).....44.4 x 483 x 263.6 mm
 Weight..... 1.3 kg



This equipment is designed and manufactured to conform to the following EC standards:
 EMC: EN 55103-1/E1, EN 55103-2/E5, EN 50130-4, EN 50121-4, EN 61000-6-2 and EN 61000-6-3
 Safety: EN 60065 (pollution degree 2)

Manufacturer

Application Solutions (Safety and Security) Limited
 Unit 17 - Cliffe Industrial Estate - Lewes - East Sussex - BN8 6JL - U.K.
 Tel: +44(0)1273 405411

www.asl-control.co.uk

All rights reserved.
 Information contained in this document is believed to be accurate, however no representation or warranty is given and Application Solutions (Safety and Security) Limited assumes no liability with respect to the accuracy of such information.



Assessed to ISO 9001
 LPCB Cert No: C1043

SPECIFICATION

Power

Quiescent Current (Normal)..... 15mA

Quiescent Current (Loop Return Mode)..... 39mA

Audio Processing

Gain -60 to +10 dB

Gate Configurable Threshold / Attack / Hold Release

EQ..... 10 Band Parametric

Interfaces

Audio Input..... 0dB Balanced Analogue Audio

Loudspeaker Monitoring DC, Loop Return

Loudspeaker Outputs..... Dual A and B outputs

Environmental

Operating -10°C to +55°C

Storage -20°C to +55°C

Humidity Range 0% to 93% non-condensing

Mechanical

Dimensions 64 mm x 30 mm x 121 mm

Weight..... 0.15 kg

IP Rating IP20 as part of V2000 frame



This equipment is designed and manufactured to conform to the following EC standards:
EMC: EN 55103-1/E1, EN 55103-2/E5, EN 50130-4, EN 50121-4, EN 61000-6-2 and EN 61000-6-3
Safety: EN 60065 (pollution degree 2)

Manufacturer

Application Solutions (Safety and Security) Limited
Unit 17 - Cliffe Industrial Estate - Lewes - East Sussex - BN8 6JL - U.K.
Tel: +44(0)1273 405411

www.asl-control.co.uk

All rights reserved.

Information contained in this document is believed to be accurate, however no representation or warranty is given and Application Solutions (Safety and Security) Limited assumes no liability with respect to the accuracy of such information.



Assessed to ISO 9001
LPCB Cert No: C1043

